

ClanPro®

STRONG-ARM



ENGINE STAND
MODEL NO: CES340
PART NO: 7610124

**UK
CA**

USER INSTRUCTIONS

ORIGINAL INSTRUCTIONS

DL0922 Issue 4

INTRODUCTION

Thank you for purchasing this CLARKE Engine Stand.

Before attempting to operate the product, it is essential that you read this manual thoroughly and carefully follow all instructions given. In doing so you will ensure the safety of yourself and that of others around you, and you can also look forward to the stand giving you long and satisfactory service.

GUARANTEE

This CLARKE product is guaranteed against faulty manufacture for a period of 12 months from the date of purchase. Please keep your receipt as proof of purchase.

This guarantee is invalid if the product is found to have been abused or tampered with in any way, or not used for the purpose for which it was intended.

Faulty goods should be returned to their place of purchase, no product can be returned to us without prior permission.

This guarantee does not effect your statutory rights.

TECHNICAL SPECIFICATIONS

Max Capacity	340 kg (0.34 Tonne)
Net Weight	18 kg
Dimensions L x W x H	800 x 760 x 900

SAFETY PRECAUTIONS

1. Do not allow personnel to use the stand unless they have read these safety precautions.
2. Never tamper with the product or modify it in any way, as this could prove to be dangerous and will invalidate the guarantee. Only use the product for the purpose for which it is intended.
3. Ensure that the stand is in good working order. Have any damaged parts repaired or replaced immediately. Use genuine Clarke parts only. The use of unauthorised parts may be dangerous and invalidate the guarantee.
4. Do not use the stand if it is damaged.
5. Use the stand in a suitable, well lit work area.
6. Keep the work area clean and tidy and free from unrelated items.
7. Do not use the stand when you are tired or under the influence of alcohol, drugs or intoxicating medication.
8. Use the stand on level and solid ground, preferably concrete. Avoid soft/ unmade ground as the castors may sink in.
9. Ensure all bystanders keep at a safe distance whilst the stand is in use.
10. Do not work underneath an engine mounted on the stand.
11. Never climb on, or attempt to ride on the stand.
12. Take care not to trap your fingers in the adjustable parts of the stand.
13. Due to the weight of the loaded stand, the help of an assistant will be beneficial when moving the stand around.
14. Never attempt to move a loaded engine stand across a floor having cracks, pebbles, or other obstacles which might impede its movement.
15. The components of this engine stand are designed to withstand the rated capacity. Do not substitute any other components or exceed the rated capacity of the stand.
16. To move a loaded stand, push it from the load side. DO NOT move the stand from the handle end and never pull the stand towards yourself.
17. Always ensure the engine is properly bolted to the stand.
18. Do not over-reach. Keep your proper footing and balance at all times.
19. Safety equipment such as gloves and non-skid shoes will reduce personal injuries.
20. Failure to heed these warnings may result in damage to the equipment, or serious personal injury.

UNPACKING

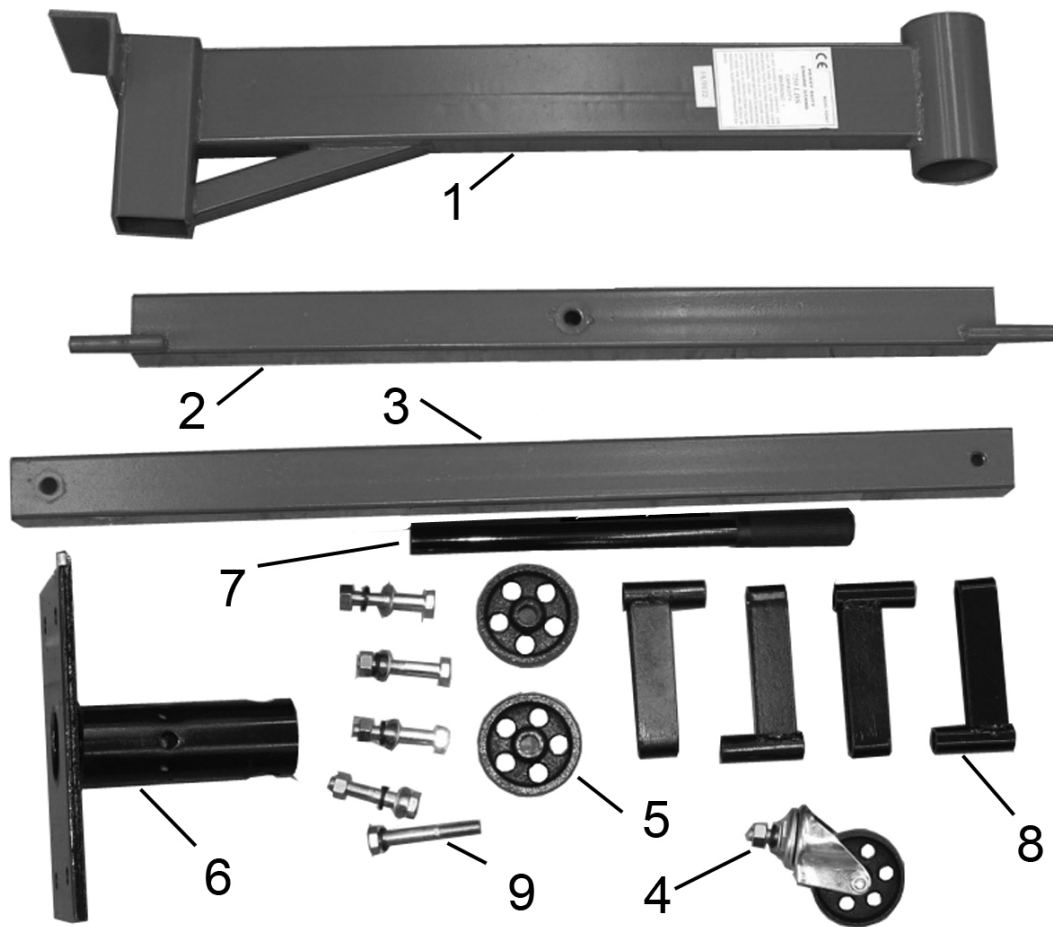

CONTENTS

Unpack the components on a clean flat area of hard standing, and ensure that all parts are present according to the packing list, as follows:

1	1 x Support column
2	1 x Rear cross-member
3	1 x Front leg
4	1 x Castor with brake
5	2 x Rear wheels

6	1 x Engine mounting plate
7	1 x Mounting plate handle
8	4 x Engine mounting arms
9	1 x Fixings kit including nuts, bolts, washers and locating pin.

Visually inspect all components to ensure that no damage was suffered in transit. Any deficiencies should be reported to your CLARKE dealer immediately.

TOOLS REQUIRED

- Open or ratchet ring spanner (19 mm) or an adjustable wrench.

ASSEMBLY

IMPORTANT: Due to the weight of the components, we recommend that you get assistance during assembly.

- Slide the front leg into the socket at the base of the main support column and sit together on the rear cross member. Use the 70mm bolt, washers & nut to connect all three items together.
 - Check that the leg and cross member are at right angles using a set square before tightening the bolt fully.
- Fit the rear wheels to each stub axle on the rear cross-member and secure them with a flat washer and split pin.
- Attach the castor to the front leg, using the nut, flat washer and spring washer.
- Fit the engine mounting plate to the column & secure with the pin.
- Loosely attach the engine mounting arms to the mounting plate with 60mm bolts, nuts, and washers.
- Pass the handle through the hole in the spindle of the mounting plate.

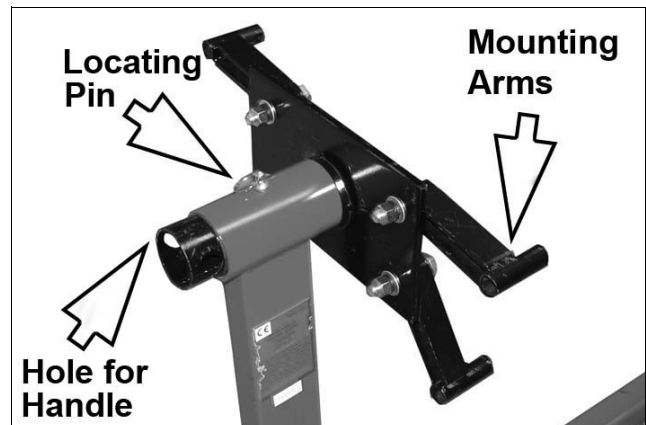
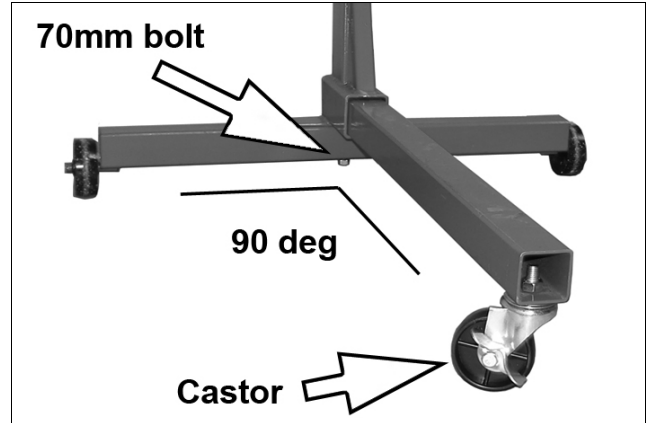

MOUNTING THE ENGINE TO THE STAND

- The mounting plate has four adjustable mounting arms with long bolt holes. This is where the engine will mount to the mounting plate, using suitable bolts which are compatible with the threaded holes in the engine block.
- If the bellhousing bolts are too short, obtain bolts that have the same diameter and thread pitch. Ideally, the bolts must be long enough to go through the mounting plate arms and go at least one inch into the engine block.
- Lift the engine with your engine hoist and move it towards the stand.

4. Remove the locating pin, then remove the mounting plate assembly from the engine stand.
5. Using compatible bolts, pass them through the mounting arms and bolt them to the engine where the transmission was mounted to the block. Mount two arms low down on the engine and bolt the other two as high as possible.
6. Adjust the arms on the engine stand mounts so that the centre of the mounting plate is aligned with the centre of the engine crankshaft. By doing this you can ensure that the engine is balanced on the stand. Tighten the bolts securely.
7. Lower the engine until the pivoting center is at the same level as the engine stand. Slide the pivoting centre of the mount into the engine stand. Replace the locating pin to secure the mounting.
8. Slowly lower the engine hoist so that the engine stand starts to support the weight of the engine. Double-check all fasteners and be sure that the engine stand is locked in place.
9. Once you are confident that the stand is supporting the weight of the engine, disconnect the hoist. Now that the engine is mounted to the stand it can be rotated around to access all sides of the engine. Use the locking pin to lock the engine at one of four different working angles.



MAINTENANCE

1. Always visually inspect the stand before use, to ensure that all parts are correctly located and secure. Check for cracks, deformation or other signs of damage and check the castors for damage. Do not use the stand unless it is totally sound.
2. Check castors to ensure they move freely without undue wear to their pivots, and that the wheels are not cracked or damaged.
3. Remove any rust or corrosion and repaint for protection.

PARTS DIAGRAM

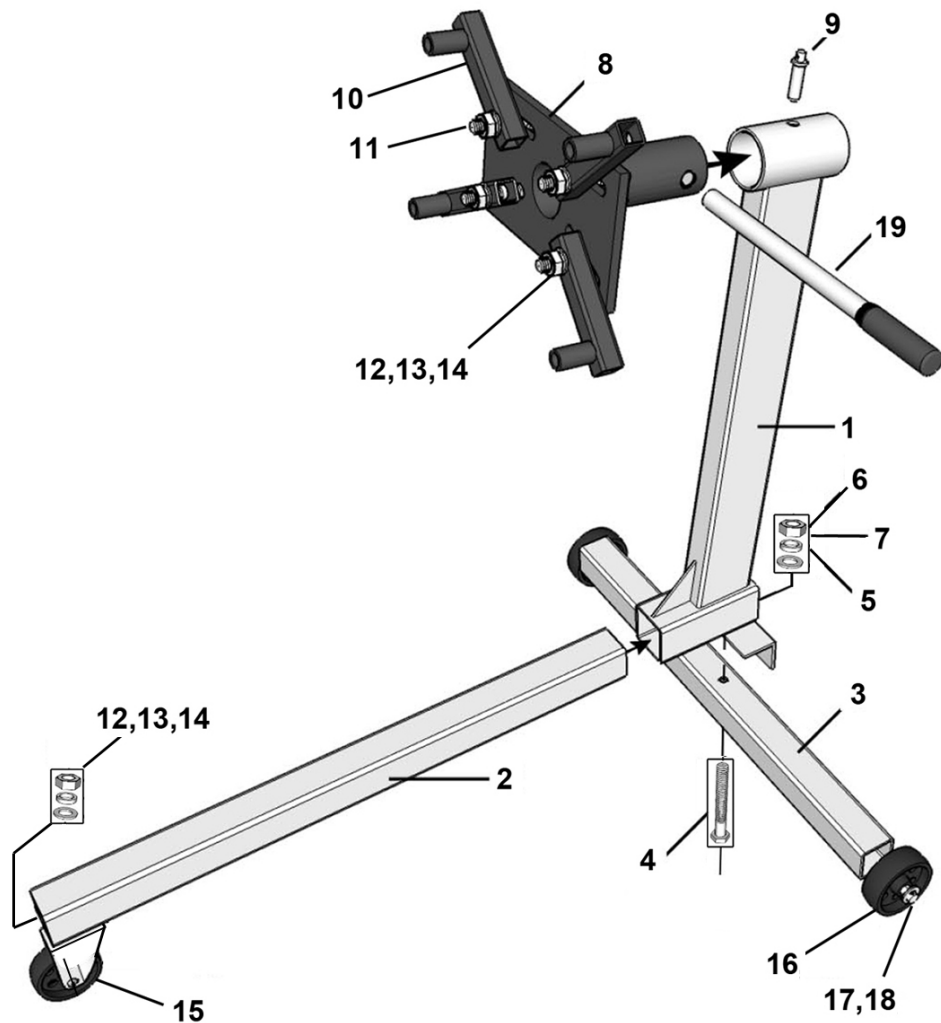

PART NO	DESCRIPTION
1	Column
2	Front Leg
3	Cross-member
4	Bolt (M10 x 70)
5	Washer flat M10
6	Hex Nut (M10)
7	Spring Washer M10
8	Engine Mounting Plate
9	Locking Pin
10	Engine Mounting Arm

PART NO	DESCRIPTION
11	Bolt (M14 x 60)
12	Spring Washer M14
13	Flat Washer
14	Hex Nut
15	Castor with brake
16	Rear Wheel
17	Flat Washer
18	Spring Pin
19	Handle

A SELECTION FROM THE VAST RANGE OF

Clarke®

QUALITY PRODUCTS

AIR COMPRESSORS

From DIY to industrial, Plus air tools, spray guns and accessories.

GENERATORS

Prime duty or emergency standby for business, home and leisure.

POWER WASHERS

Hot and cold, electric and engine driven - we have what you need

WELDERS

Mig, Arc, Tig and Spot. From DIY to auto/industrial.

METALWORKING

Drills, grinders and saws for DIY and professional use.

WOODWORKING

Saws, sanders, lathes, mortisers and dust extraction.

HYDRAULICS

Cranes, body repair kits, transmission jacks for all types of workshop use.

WATER PUMPS

Submersible, electric and engine driven for DIY, agriculture and industry.

POWER TOOLS

Angle grinders, cordless drill sets, saws and sanders.

STARTERS/CHARGERS

All sizes for car and commercial use.

**UK
CA**

Clarke®
INTERNATIONAL

Hemndall Street, Epping, Essex CM16 4LG

DECLARATION OF CONFORMITY

This is an important document and should be retained.

We hereby declare that this product(s) complies with the following statutory requirement(s):

Supply of Machinery (Safety) Regulations 2008

The following standards have been applied to the product(s):

EN ISO 12100:2010

The technical documentation required to demonstrate that the product(s) meet(s) the requirement(s) of the aforementioned legislation has been compiled and is available for inspection by the relevant enforcement authorities.

The UKCA mark was first applied in: 2022

Product Description: Engine Stand 340kg
Model number(s): CES340
Serial / batch Number: N/A
Date of Issue: 13/09/2022

Signed:



J.A. Clarke
Director